

**Clearances:**

"A" = Horizontal distance to adjacent surface  
 100mm if smooth, 325mm if irregular

**Anchors**

Horizontal & Vertical 2 minimum (see installation information)  
 for further details of substrate requirements and type

**Platform Floor Finish**

Standard - Aluminium Chequer Plate  
 Special - Altro walking 20

**Electrical Supply (Main switch)**

1ph L, N, PE, 3 x 2,5mm<sup>2</sup> 16A

**Technical Data**

Rated capacity: 300kg / 2 Persons  
 Speed: 0,08m/s  
 Drive: 2,5 kw Electrical Motor / Belt drive  
 Electrical Connection: Single phase, 3 x 1,5mm<sup>2</sup>  
 (By use of heater the cable area should be increased to 2,5mm<sup>2</sup>)  
 Control Voltage: 24 Volts  
 Soft Start / Stop by frequency inverter  
 Drive system: Screw / nut, dubble

HORIZONTAL FORCES	
Fixing height mm	Total Anchor Force Fa. kN
400	21.5
600	17.0
800	14.5
1000	11.0
1200	8.5
1400	7.5
1600	6.5
1800	5.5
2000	4.5
2200	4.0
2400	3.5
2600	3.25
2800	3.0

Fb = Vertical force of 10kN, spread over area of 1300mm x 250mm.

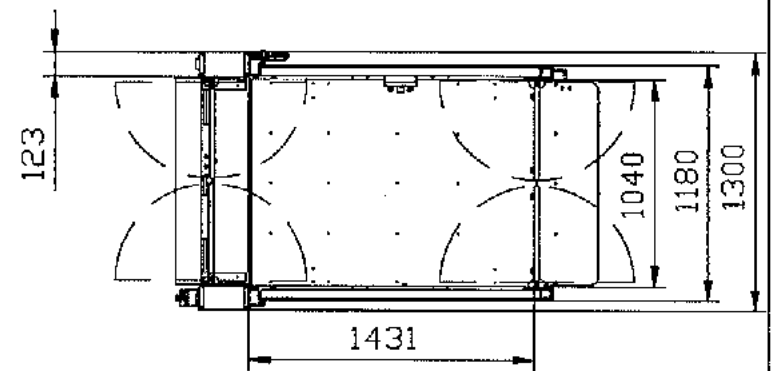
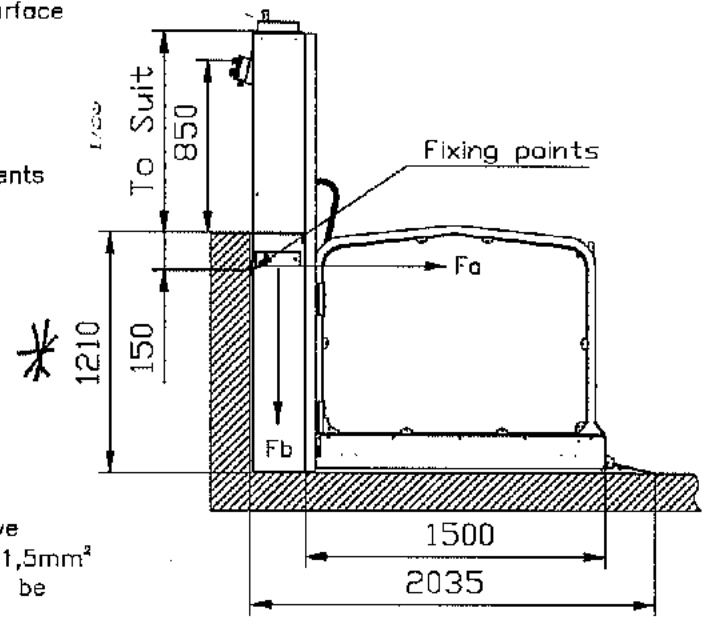

\* VARIABLE BETWEEN 500MM - 3000MM

	Invalifts Ltd	